

# Exhibitor Prospectus

**THE 29TH ANNUAL  
TELECOMMUNICATIONS CONFERENCE &  
EXHIBITION**

**CHECK OUT THE**

**New Business  
Opportunities**

**ON PAGE 2**

# PTC '07

## Beyond Telecom

**CONFERENCE: 14-17 JANUARY 2007**

**EXHIBITION: 15-16 JANUARY 2007**

**HILTON HAWAIIAN VILLAGE® BEACH RESORT & SPA**

**HONOLULU, HAWAII USA**

**[WWW.PTC07.ORG](http://WWW.PTC07.ORG)**



**Pacific Telecommunications Council**

2454 South Beretania Street, Suite 302

Honolulu, Hawaii 96826 USA

Telephone: +1.808.941.3789

Facsimile: +1.808.944.4874

Email: [ptc07@ptc.org](mailto:ptc07@ptc.org)

Website: [www.ptc.org](http://www.ptc.org)

# PTC'07 EXHIBITOR PROSPECTUS

## Beyond Telecom

14 – 17 January 2007 • Honolulu, Hawaii USA • www.ptc07.org

### Venue

Hilton Hawaiian Village® Beach Resort & Spa, 2005 Kalia Road, Honolulu, HI 96815-1999, USA  
Tel: +1.808.949.4321, Fax: +1.808.947.7898

### What is the Mid-Pacific Marketplace (MPM)?



Showcase your latest technologies and reach qualified leads at PTC's revamped exhibition now called the "Mid-Pacific Marketplace" (MPM). For the first time ever, PTC is consolidating its trade show; Planet PTC Cyber café; coffee lounge; session coffee breaks; conference luncheons; marketplace reception; and new business meeting modules into one dynamic space. The expanded trade show floor will be a beehive of activity as exhibitors, conference delegates, and networkers interact for two full days of intense deal-making. Reserve your space now and join us at PTC'07!

#### Access new benefits:

- The "One-2-One Exchange" meeting tables
- Themed "Marketplace" reception on Tuesday evening
- Conference coffee breaks to be held in the MPM
- Exhibitor contacts to be included in attendees list
- Access to all plenary sessions

#### Continue to receive key marketing benefits:

- Conference luncheons are held in MPM
- Access attendee list for marketing communications
- Press coverage before and during PTC'07
- Free passes to selected conference sessions
- Company exposure online; in printed materials and in onsite promotions

and a whole lot more!

### PTC'07: Beyond Telecom

The theme for PTC'07 is Beyond Telecom. The conference will explore the technology, business and policy issues created by the accelerated and continued convergence of communication and entertainment services on IP. Leading providers from Asia and around the world will discuss successful strategies for advanced information services, video, youth and lifestyle marketing, cyber communities and gaming. Policy makers will explore the options and impact of next generation service licensing, net neutrality and IPTV. Vendors will demonstrate the infrastructure platforms and consumer devices that enable the transition to forward-looking business models. Satellite, fiber and VoIP CEOs will share their vision through annual executive roundtables. And PTC'07 will continue PTC's commitment to illuminate the positive role IP and low-cost access technologies can play in humanitarian relief, disaster management, distance learning, health care, social advancement and poverty reduction.

### What is PTC?

The Pacific Telecommunications Council (PTC) is the leading professional organization promoting the advancement and commercial use of Information and Communication Technologies (ICTs), services, policies, and knowledge to benefit its members and the people of the Pacific Hemisphere.

PTC was formed in 1979 with a mission to facilitate the adoption of telecommunications and advanced information technologies throughout the Asia Pacific region. With approximately 3,000 member representatives from over 60 countries worldwide, PTC enables the exchange of ideas and commerce that is critical to social and economic progress in the Asia-Pacific Region.

PTC advances education and commerce around ICTs primarily through its annual conference in Honolulu, Hawaii. Scholars, government officials, policymakers, users and commercial executives from Asia, the Americas and Europe have come together each January for the past 28 years to learn, share and network together. The PTC conference has truly become the one "must-attend" event in the Pacific hemisphere for the entire community.

### Why should you exhibit at PTC'07?

Now in its 29th year, PTC's annual Conference & Exhibition continues to offer the best one-stop exposure and setting to interact with major stakeholders in the Asia-Pacific region. PTC'07 is a must for those doing business in this area to make useful industry contacts, meet new customers, announce new products, services, contracts and ventures to an international audience of senior executives at the Hilton Hawaiian Village® Beach Resort & Spa, located on world famous Waikiki Beach in Hawaii. The conference has long been the most important event that ties Asia to the Americas and the rest of the world. PTC'07 is where the leaders will start the New Year, and we invite you to join them.

***"Cordell Inc. has been attending the PTC for more than 15 years. (I believe this will be our 19th or 20th year). During this time, the PTC has been one of the best performing and most productive shows of the 17 we participate in annually. In the past few years, it can be directly credited with more than \$500,000 in sales for Cordell.***

***We have found it to be a great place to meet decision makers for most of the companies throughout the Pacific. This saves time and the expense of travel and allows Cordell an opportunity to bring its best people and new products to a central location to meet our customers."***

— WILLIAM E. MATHEWS, III, PRESIDENT AND CEO, CORDELL, INC.

**Who will be at PTC'07?**

- Experts from Internet Community
- Top Executives from Carriers, Suppliers, Broadcasters and User Organizations
- Providers and Users of Communications Services and Information Technology
- Senior Representatives from International and Regional Organizations
- Policy Makers and Government Officials
- Content Providers
- Technologists
- Lawyers
- Scientists and Engineers
- Academics
- International Consultants

**Past Exhibitors Included**

**Senior Executives from nearly 60 countries converge on Honolulu during PTC's annual conference & exhibition**

Agiosat Global Communications	Freeway Communications, LLC	MetaSwitch	pulverInnovations	Telecom Asia Group/ America's
AIRAYA	Globecom Systems	NACT Telecommunications	Qualmax, Inc.	Network/ Questex Media
Alvarion, Inc	Heliuss, Inc.	NAS Wireless	Quintrex Data Systems	Group, Inc.
Arianespace, Inc.	Homisco, Inc.	net.com	Qwest Communications	TeleGeography Research
Boeing	iDirect Technologies	NetworkIP	REDCOM	Telic Communications, Inc.
Canada West Telecom Group	Infozech Software, Inc.	NeuStar, Inc.	RF Window Co., Ltd.	Time Warner Telecom of Hawaii
Cantata (formerly named	Intelsat	New Skies Satellites	Satnews Publishers	TransNexus
Excel Switching/Brooktrout	Interactive Content Engines,	NexTone	Seawolf Technologies, Inc.	TransTeleCom
Technology)	LLC	Omnitron Systems Technology,	SecureMedia	Turin Networks
Capacity Magazine	International Engineering	Inc.	SED Systems	Ulysses Consulting
Carlson Wireless Technologies,	Consortium	Orca Wave	sentio Networks	Universal Telecom Services,
Inc.	IOT Systems, LLC	Oregon Fishermen's Cable	SilkWater Technologies, LLC	Inc.
Cordell, Inc.	IP Access International	Committee	SIP Forum	Veraz Networks
CRG West, LLC	JSAT Corporation	Pacific LightNet	Solectek Corp.	Verestar, Inc.
CTC Marine Projects	Konfer Technologies, Inc.	Communications	SonicWALL	Via Satellite
Dragon Telecom Co., Ltd.	Lyman Bros.	Pacific Wireless	Tekelec	ViaSat, Inc.
EdgeAccess, Inc.	MCI	Communications	Telcordia Technologies	VOIP International, Inc.
France Telecom	MediaRing, Ltd.	PanAmSat		WFN Strategies

**PTC'06 Attendee Profile:**

**PTC Attracts Senior Executives**

Note: C-Suite category includes Chairman, Presidents, CEO, COO, CFO, CTO & CIO  
Others category includes Founders, Academic, Board Members & Department Heads

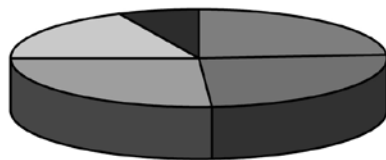

**PTC'06**

- C-Suite / 24%
- Vice Presidents / 25%
- Directors / 26%
- Managers / 18%
- Others / 7%

**Nearly 60 Countries Represented**

Total number of participating countries at PTC'06 was 58.

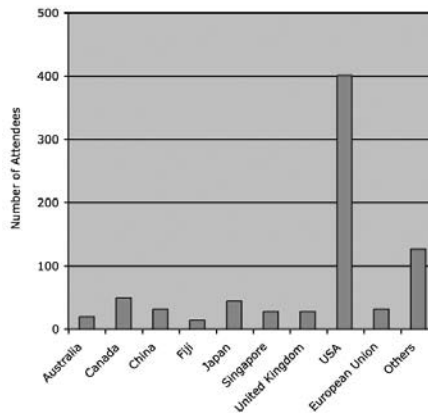

**PTC'06 Attendees' Interests**

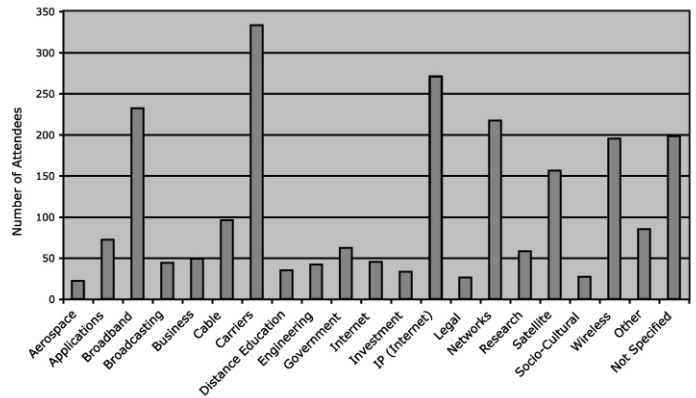

## Exhibit Rates

PTC MEMBER RATE	PTC NON-MEMBER RATE
\$2,600 per booth or \$32.50 per square foot	\$3,500 per booth or \$43.75 per square foot

## Exhibit Package



1. All exhibit booths are standard pipe and drape spaces. Each Exhibitor is furnished with chrome supports and aisle posts with 8 feet (2.44 meters) high back divider and 3 feet (.91 meter) high side dividers from which flameproof drapes are suspended. An identification sign (7" x 44" / 17.8 cm x 111.8 cm) with the Exhibitor's name and booth number will be provided.
2. A 100 to 150-word company profile, logo, and list of products/services promoted at the booth (provided by the Exhibitor) are published in the final program and distributed to all conference delegates.
3. PTC'07 Online Promotion – Rotating company logo, Online Exhibit Hall, company profile with logo, two pictures of company products and a Business Card Drop feature that allows potential clients and partners to contact exhibitor before, during and after the event on the PTC'07 exhibit website.
4. Exhibitor press announcement to promote new products and services on PTC'07 exhibit website.
5. Press coverage before and during PTC'07.
6. Exhibitor press kits can be distributed in the PTC'07 press room.
7. A company logo and 40-word description promoting the products and services at exhibitor's PTC'07 booth(s) will be distributed to PTC'07 attendees via email. (Optional)
8. Lunches and coffee breaks in the Exhibit Hall.  
Monday, 15 January 2007 Lunch and Conference Session Coffee Breaks  
Tuesday, 16 January 2007 Lunch and Conference Session Coffee Breaks
9. Two (2) complimentary Opening Reception tickets for each 8' x 10' exhibit booth space purchased.
10. Marketplace Reception in the Exhibit Hall on Tuesday, 16 January 2007. Exhibitors will receive two (2) complimentary tickets for each 8' x 10' exhibit booth space purchased. **NEW**
11. Six (6) complimentary exhibitor badges for each exhibit booth space purchased.
12. Four (4) complimentary plenary session passes, two (2) complimentary regular session passes and ten (10) complimentary 1-Day Exhibit Pass for exhibitor's guests.
13. Complimentary access to all plenary sessions. **NEW**
14. A preliminary opt-in PTC'07 attendee list will be made available in early December to assist your promotional efforts. A final opt-in PTC'07 attendee list will be distributed to exhibitors after the conference.
15. Inclusion of exhibitor contact information in the PTC'07 attendee list **NEW**
16. Complimentary access to one-2-one meeting tables for two 30-minute time slots for each 8' x 10' exhibit booth space purchased per day (Optional) **NEW**
17. Complimentary coffee vouchers for the coffee kiosk in the PTC Mid-Pacific Marketplace. **NEW**
18. Two complimentary delegate bags for each exhibit booth space purchased. **NEW**
19. A 10% discount on PTC'07 conference registration rates and advertising rates.
21. A 20% discount on PTC'07 literature bin rates.

## Exhibit Hours & Exhibit Area Function

(subject to change)

Exhibit Hours			
Monday, 15 January 2007	1000 – 1800	Tuesday, 16 January 2007	1000 – 1900
<b>Marketplace Reception</b>			
Tuesday, 16 January 2007	1730 – 1900		
<b>Coffee Break</b>			
Monday, 15 January 2007	1045 – 1115	Tuesday, 16 January 2007	1045 – 1115
	1500 – 1530		1500 – 1530
<b>Lunch in Exhibit Hall</b>			
Monday, 15 January 2007	1215 – 1330	Tuesday, 16 January 2007	1215 – 1330

## Exhibitor Registration

Saturday, 13 January 2007	1500 – 1800
Sunday, 14 January 2007	0800 – 1800
Monday, 15 January 2007	0730 – 1800
Tuesday, 16 January 2007	0800 – 1900
Wednesday, 17 January 2007	0800 – 1200

***"For more than a quarter century, the Pacific Telecommunications Council has provided for the venue and infrastructure to bring together Service Providers, Manufacturers and Consultants in the Pacific Rim Basin. The Premier Conference and Exhibition held every January in Waikiki, Oahu, Hawaii, lays the basis for networking and technical interchange for the many countries and their communications service providers in the region.***

***REDCOM Laboratories Inc. has participated as a speaker, committee member, and as an exhibitor almost from the beginning of the PTC. This annual Conference greatly contributed to the success of REDCOM in placing Telecommunication infrastructure equipment to many Island Nations in the South Pacific. This entire event, and its coinciding PITA meeting, is vital to assure continuation of keeping the Pacific regional telecom companies abreast of communications technologies and their economical application for the people of the Pacific."***

— KLAUS GUELDPFENNIG, PRESIDENT, REDCOM LABORATORIES INC.

---

**Exhibitor  
Move-In**

Sunday, 14 January 2007 0800 – 1800  
Monday, 15 January 2007 0730 – 1000

Exhibit booths must be completely assembled by 1000 on Monday, 15 January 2007. Exhibitors are required to pick up their exhibitor badges at the Exhibitor Registration Desk located in the Coral Lounge in the 6th Floor of Mid-Pacific Conference Center, prior to setting up their booth. An exhibitor badge is required to access the Exhibit Hall for set-up, breakdown, and during non-exhibit hours.

For exhibit booth display restrictions, please refer to the enclosed PTC'07 Exhibit Rules and Regulations. In the event that your exhibit booth has not been assembled before the exhibits open, or if your organization fails to set-up a booth, or you do not comply with the stated exhibit restrictions, your Exhibitor benefits will be forfeited.

---

**Exhibitor  
Move-Out**

Tuesday, 16 January 2007 1930 – 2130  
Wednesday, 17 January 2007 0800 – 1100

Your exhibit booth must be dismantled and moved out of the exhibit hall by 1100, Wednesday, 17 January 2007. (ICES) International Convention & Event Services, PTC's official exhibit contractor, will work with you directly to ensure a timely move-out. Exhibitors are responsible for their exhibit material until it is moved out of the exhibit hall. In the event that your exhibit booth has not been dismantled by 1100 on Wednesday, 17 January 2007, your Exhibitor benefits will be forfeited.

---

**Exhibit Contractor**

PTC is not responsible for any exhibit support services provided to Exhibitors. Arrangements for furniture, labor, electrical, power, drayage, signs, booth furnishings and additional support services will be handled by the official exhibit contractor, ICES. Charges will be billed directly to exhibitors. **An Exhibitor Kit with the necessary forms will be forwarded to you upon receipt of your PTC'07 Exhibit Contract and deposit to the PTC office. Advance price deadline is 15 December 2006.**

All inquiries on contractor services should be directed to:

ICES  
Attn: Tanya Lasconia  
1004 Makepono Street  
Honolulu, HI 96819 USA  
Tel: +1.808.832.2440  
Fax: +1.808.832.2431  
Email: tanyal@iceshawaii.com

ICES will maintain a service desk in the exhibit area during the installation and dismantling periods as well as official exhibit hours.

Customs clearance, bonding and arrangements for importation and repatriation of exhibit materials to the country of origin is solely the responsibility of the exhibitor or their appointed customs agent or representative. Please allow sufficient time to complete these procedures.

Ship Prepaid. **IMPORTANT:** All Exhibitors are urged to work through ICES. Where possible, all crated display material should be shipped in advance to the official contractor.

---

**Security**

PTC will provide crowd control/admittance security during the hours the exhibit area is closed for move-in, show days and move-out. However, the exhibitors are solely and completely responsible at all times for their own exhibit material, equipment and personal property. Due to security reasons, no meetings may take place in the exhibit hall when the exhibits are closed.

---

**Hotel  
Accommodations**

Make your reservations early to ensure a room at the PTC'07 conference venue. Discounted conference guest room rates are available to all PTC'07 exhibitors at the Hilton Hawaiian Village® Beach Resort & Spa. Exhibitors entitled to this discounted rate must be registered as Exhibit Personnel who man the booth. All room reservations must be submitted via the Hilton online reservation page (Note: Reservation will begin at a later date) and received by **14 December 2006** to qualify for the PTC rate. Rooms are on a space available basis only. Hotel accommodations and services are the sole responsibility of exhibitors.

Hilton Hawaiian Village® Beach Resort & Spa  
2005 Kalia Road  
Honolulu, HI 96815-1999  
USA  
Tel: +1.808.949.4321  
Fax: +1.808.947.7898

For suite reservations, please email [hnlhvhh.ptcres@hilton.com](mailto:hnlhvhh.ptcres@hilton.com).

---

**Telecommunications  
Services**

Hilton Hawaiian Village® Beach Resort & Spa will provide telecommunications and high speed Internet services for exhibitors. The hotel must receive exhibitor requests for high speed Internet and telecommunication services by **30 November 2006**. A Telecommunications and Internet order forms are available in the Exhibitor Resources section of the PTC'07 website ([www.ptc07.org](http://www.ptc07.org)). For further information on telecommunications services, please contact:

Jayne McElroy  
Telecom Manager  
Hilton Hawaiian Village® Beach Resort & Spa  
Tel: +1.808.947.7895  
Fax: +1.808.947.7970  
Email: [jayne\\_mcelroy@hilton.com](mailto:jayne_mcelroy@hilton.com)

# PTC'07 EXHIBITOR CONTRACT

## Instructions

1. Carefully read the RULES AND REGULATIONS for exhibiting at PTC'07. Complete and sign this exhibitor contract and remit with a 50% deposit of the total exhibit booth rental fee to secure rental space. Please send contract and payment to:

Dolores Fung  
 Pacific Telecommunications Council (PTC)  
 2454 S. Beretania St., Ste. 302  
 Honolulu, HI 96826-1596  
 Tel: +1.808.941.3789  
 Fax: +1.808.944.4874

Or apply online at [www.ptc07.org](http://www.ptc07.org)

2. Email a 100- to 150-word company profile with full contact information, logo and list of product / services to be promoted in your booth(s) to [dolores@ptc.org](mailto:dolores@ptc.org) for your PTC'07 Promotion (with receipt of Exhibitor contract and payment.)

## EXHIBITOR CONTACT INFORMATION

Provide complete contact information for the person who will be responsible for PTC'07 exhibit arrangements. All arrangements and correspondence will be directed to this individual. This contact is responsible to inform all exhibit personnel of the PTC'07 Rules and Regulations.

Mr.  Ms.  Dr. (please print clearly)

Name: \_\_\_\_\_

Title: \_\_\_\_\_

Company / Organization: \_\_\_\_\_

Mailing Address: \_\_\_\_\_

City: \_\_\_\_\_ State / Province: \_\_\_\_\_

Zip / Postal Code: \_\_\_\_\_ Country: \_\_\_\_\_

Telephone (include Country Code): \_\_\_\_\_

Facsimile (include Country Code): \_\_\_\_\_

Email: \_\_\_\_\_

(Alternate contact) Name: \_\_\_\_\_

Telephone (include Country Code): \_\_\_\_\_

Email: \_\_\_\_\_

Please indicate any special needs: \_\_\_\_\_

**IMPORTANT NOTE:**  
**Booth personnel are required to wear their badges at all times while in the Exhibit Hall. BADGES ARE NON-TRANSFERABLE. PTC staff and security will refuse entry and escort out any person not wearing an appropriate badge. PTC reserves the right to confiscate misused booth-personnel badges.**

## HOW DID YOU LEARN ABOUT PTC'07?

- |   |   |
|---|---|
| <input type="checkbox"/> E-mail                           | <input type="checkbox"/> Web site         |
| <input type="checkbox"/> Friend or professional colleague | _____                                     |
| <input type="checkbox"/> Previously attended              | <input type="checkbox"/> Advertisement in |
| <input type="checkbox"/> PTC Member                       | _____                                     |
| <input type="checkbox"/> PTC'07 Brochure                  | <input type="checkbox"/> News article in  |
| <input type="checkbox"/> PTC'07 Exhibitor Prospectus      | _____                                     |
| <input type="checkbox"/> PTC'07 Flyer at another event    | <input type="checkbox"/> Other            |
|   | _____                                     |

## DATA THAT HELPS YOU NETWORK

To indicate the sectors most closely associated with your activities, please place a '1' in the category box which best describes your **primary business or industry sector**. Please **check two** other categories which are of **interest** to you. This valuable information will be made available to other registrants who may be interested in contacting you, or in doing business with someone in your field while you are at PTC'07.

### Telecom Carrier

- Local Exchange Carrier (LEC/LEC/IOC)
- Competitive Access Provider (CLEC)
- Wireless (Cellular/PCS)
- Wireless (Wi-Fi, WiMAX)
- Internet Telephony Provider (VoIP)
- Interexchange Carrier (IXC)
- Cable Telecommunication Provider/Operator
- Internet Service Provider
- Satellite Service Operator
- Satellite Carrier
- Backbone Network/Fiber Network:
  - Terrestrial;  Submarine Cable; or
  - Both
- Data LEC (DLEC)
- Integrated Communications Provider
- Public Utility/Power Grid Operator
- Virtual Private Network Provider (VPN)
- Broadcaster
- Network Service Provider

### Telecom Manufacturer / Distributor

- Equipment Manufacturer
- Dealer/Distributor/Agent
- VAR
- Carrier Service Reseller
- Outside Plant

### Software and Content

- Software Developer
- Content Provider
- Content Creation
- Content Production
- Content Distribution
- Content Security

- Digital Rights Management
- Encryption

### Financial

- Investment Analyst
- Broker
- Financial Services
- Investment Banking
- Venture Capital

### Telecom Services

- Legal Services
- Consulting Services
- Contractor
- Engineering
- Systems Integrator
- ASP/AIP/Web Hosting/Videoconferencing
- Billing
- Customer Care

### Enterprise

- Applications
- Software Developer
- Network Administrator

### Government / Military / Regulatory / Education

- Government (municipal, state, federal)
- Government/Regulator
- Education
- Military

### Association

- Trade
- Professional
- Other (Please specify): \_\_\_\_\_

**BOOTH IDENTIFICATION SIGN**

ICES, the PTC'07 Exhibitor Contractor, will provide a Booth Identification Sign for your exhibit space. Please indicate how the name of the company should appear on the two-line standard sign (7"x44" / 17.8 cm x 111.8 cm).

**PREFERENCES**

Please indicate any company or type of company you do not wish to be located next to:

**BOOTH SPACE SELECTION**

Please refer to the Exhibit Layout on page 12 to select desired booth(s) in order of preference. Space is assigned on a first-come first-served basis upon receipt of contract and payment.  
 1st \_\_\_\_\_ 2nd \_\_\_\_\_ 3rd \_\_\_\_\_

**EXHIBIT RATES AND PAYMENT INFORMATION**

Each rented 8'X10' exhibit booth is entitled to: six (6) complimentary exhibitor badges, two (2) complimentary Opening Reception tickets and Exhibit Reception tickets. Children under 21 are not allowed to attend any PTC functions. Additional Opening Reception Tickets may be purchased for Exhibitor Personnel only at \$60 each.

_____ (8'x10') Booth(s) x \$2,600 (PTC Member Rate)	\$ _____
_____ (8'x10') Booth(s) x \$3,500 (PTC Non-Member Rate)	\$ _____
_____ Additional Opening Reception Ticket(s) x \$60 (For Exhibit Personnel Only)	\$ _____
_____ Additional Exhibitor Badge(s) x \$20	\$ _____
_____ PTC'07 Aloha Shirt(s) x \$50 (Orders will not be taken after 21 November 2006)	\$ _____
Indicate sizes:	
S    M    L    XL    XXL	
<b>TOTAL</b>	\$ _____

**PAYMENT FOR PTC'07 EXHIBIT SPACE WILL BE MADE VIA:**

- Check Enclosed (payable to Pacific Telecommunications Council)
- Please send an invoice
- Bank Transfer. See details in section #3 in Rules and Regulations
- Purchase order enclosed\*
- Bill by Credit Card
  - Visa    MC    AMEX    Diner's Club    Carte Blanche

Account No: \_\_\_\_\_

Expiration Date: \_\_\_\_\_ \*\*Credit Card's Security Code: \_\_\_\_\_

Authorized charge amount: \$ \_\_\_\_\_

Cardholder name (Print): \_\_\_\_\_

\*\* Billing Address: \_\_\_\_\_ City: \_\_\_\_\_

State/Province: \_\_\_\_\_ Zip/Postal Code: \_\_\_\_\_ Country: \_\_\_\_\_

Cardholder Signature: \_\_\_\_\_

Charge remaining balance to the same credit card.  
(Specify amount and date of charge below)

\$ \_\_\_\_\_  
 Amount \_\_\_\_\_ Date \_\_\_\_\_

\*If a P.O. is being used for payment we must receive backup credit card payment information. If payment is not made within 15 days after the conference, the credit card will be charged the outstanding payment for the PTC'07 exhibit space. Please complete the above credit card information.

\*\*For security reason, our bank requires you to provide your billing address and your credit card's 3 or 4 digit security code. For Visa, MasterCard, Diner's Club and Carte Blanche, the last 3-digit security code is on the back of credit card, in the signature panel. For AMEX, the 4-digit security code is on the right side of the front of credit card.

**AGREEMENT**

Enclosed herewith is a 50% payment of the total exhibit booth rental. If booth rental occurs after 1 November 2007, the full payment is enclosed. In applying for exhibit booth space, we agree to abide by the RULES and REGULATIONS, which are listed on pages 10–11 of this contract. In accordance, we agree to the following provisions: Exhibit booths will be assigned by PTC on the basis of the order in which the contracts and deposits are received. If the Exhibitor fails to pay the balance of the booth rental before 1 November 2007, the Exhibitor's rights to exhibit may be cancelled without further notice or refund of any deposit. If an Exhibitor cancels its participation, refunds shall be in accordance with section #4 of the RULES and REGULATIONS. Exhibitor and management shall be bound by the RULES and REGULATIONS for exhibiting at PTC'07 that has been received and considered as part of this agreement.

I have read the PTC'07 EXHIBIT RULES AND REGULATIONS and will abide by and with the preceding agreement.

Print Name: \_\_\_\_\_

Signature: \_\_\_\_\_

Date: \_\_\_\_\_

## PTC'07 EXHIBITOR BADGE FORM **Deadline: 30 November 2006**

Each 8'x10' booth space is allowed up to 6 complimentary Exhibitor Badges. Additional badges may be purchased for \$20 each. Exhibitor Badges and tickets will be included in the Exhibitor Packet available at the Exhibitor Registration desk in the Coral Lounge, 6th Floor of the Mid-Pacific Conference Center. Indicate below, the exhibitor responsible for the exhibitor packet onsite. Please review the Booth Personnel information of the RULES AND REGULATIONS, section #7.

- Exhibitor Badges allow registered booth personnel (see below) access the Mid-Pacific Marketplace during installation/dismantling of booths and official exhibit hours. Exhibitors that wish to attend the full conference sessions, tutorials/workshops, round tables, etc., must register for the conference separately and pay the appropriate member/non-member conference registration fee.
- Booth personnel are required to wear their badges at all times while in the Mid-Pacific Marketplace. **BADGES ARE NON-TRANSFERABLE. PTC staff and security will refuse entry and escort out any person not wearing an appropriate badge.** PTC reserves the right to confiscate misused booth-personnel badges
- Booth personnel are classified as exhibitor representatives who are engaged in the display, demonstration and sales of the company's products or services. If you have staff or individuals who will be involved only in the set-up of your exhibit display, please furnish their names on a separate sheet of paper to PTC in advance. A temporary pass will be issued to each of these individuals at the Exhibitor Registration Desk. Exhibitors may not permit non-exhibiting company representatives to exhibit in their booth.

Please provide the names of booth personnel requiring Exhibitor Badges for PTC'07 on this form or send the personnel list via email using the format below to Dolores Fung at [dolores@ptc.org](mailto:dolores@ptc.org). Badge information is limited to three (3) lines: name, company and country. **(Additional title, email, tel, mobile information about the exhibitor personnel can be posted on the online Exhibitor Staff list.)**

**EXHIBITING COMPANY:** \_\_\_\_\_ **BOOTH #:** \_\_\_\_\_

Individual responsible for the exhibitor packet: \_\_\_\_\_

Complete Names of the staffing team (Please print clearly):

1. **Name:** \_\_\_\_\_

**(Name provided here will be included in the final PTC'07 Conference attendee list.)**

Company (if different from above): \_\_\_\_\_ Title: \_\_\_\_\_

Address: \_\_\_\_\_

City: \_\_\_\_\_ State / Province: \_\_\_\_\_ Zip / Postal Code: \_\_\_\_\_ Country: \_\_\_\_\_

Tel: \_\_\_\_\_ Mobile: \_\_\_\_\_ Fax: \_\_\_\_\_ Email: \_\_\_\_\_

**(If providing contact information, you agree to receive information from industry colleagues.)**

2. **Name:** \_\_\_\_\_

Company (if different from above): \_\_\_\_\_ Title: \_\_\_\_\_

Country: \_\_\_\_\_ Email: \_\_\_\_\_

Tel: \_\_\_\_\_ Mobile: \_\_\_\_\_

3. **Name:** \_\_\_\_\_

Company (if different from above): \_\_\_\_\_ Title: \_\_\_\_\_

Country: \_\_\_\_\_ Email: \_\_\_\_\_

Tel: \_\_\_\_\_ Mobile: \_\_\_\_\_

4. **Name:** \_\_\_\_\_

Company (if different from above): \_\_\_\_\_ Title: \_\_\_\_\_

Country: \_\_\_\_\_ Email: \_\_\_\_\_

Tel: \_\_\_\_\_ Mobile: \_\_\_\_\_

5. **Name:** \_\_\_\_\_

Company (if different from above): \_\_\_\_\_ Title: \_\_\_\_\_

Country: \_\_\_\_\_ Email: \_\_\_\_\_

Tel: \_\_\_\_\_ Mobile: \_\_\_\_\_

6. **Name:** \_\_\_\_\_

Company (if different from above): \_\_\_\_\_ Title: \_\_\_\_\_

Country: \_\_\_\_\_ Email: \_\_\_\_\_

Tel: \_\_\_\_\_ Mobile: \_\_\_\_\_

## Exhibitor Profile

**Deadline: 30 November 2006** PTC will publish a 100- to 150-word company profile and logo, provided by the exhibitor, in the final program. Your company logo and profile with a hyperlink to your organization's website will be included in the PTC'07 Online Promotion. Only contracted companies will receive a listing in the program and conference website.



Email your company logo (eps) and profile in the following format to Dolores Fung at dolores@ptc.org with your Exhibit Contract no later than **30 November 2006**. Include contact information: (full address, telephone and fax numbers, web site and e-mail addresses). Be sure to indicate the e-mail address to be used for the Business Card Drop feature, if different from the company contact information. The Business Card Drop feature of the Online Exhibit Hall allows potential

### Profile Format

Exhibitor Company:  
Booth#:  
Company Profile (100–150 word maximum):  
List Products/Services To Be Promoted  
(40-word maximum):

Complete Mailing Address:

Tel:  
Fax:  
Email:  
Web site:  
Business Card Drop Email (if different from above):

## Promotional Opportunities

### Conference Program Advertisement

Advertise in the PTC'07 Conference Program. Exhibitors receive discounted advertising rates! The program will be used extensively during the conference and for promotional purposes throughout the year. For more information, contact Neil Bock at neil@ptc.org.

### Literature Bins

A literature area is designed for those wishing to have their organization's literature and/or publications prominently displayed and easily accessible by all conference attendees. Literature bin price is US\$150 per bin/publication through Friday, 29 December 2006. US\$200 will be charged if purchased after Friday, 29 December 2006. PTC exhibitor will receive a 20% discount on PTC'07 literature bin rates. For more information, contact Odessa Kawai at odessa@ptc.org.

### Meeting Space

Meeting space is available for a nominal fee for special seminars, demonstrations, etc. Contact Sharon Nakama at snakama@ptc.org in advance for arrangements.

### Press Conferences

Take this opportunity to announce new products, services, contracts and ventures. For more information, please email us at ptc07@ptc.org.

### Sponsorship Opportunities

Increase your organization's presence at PTC'07. This is a premier opportunity to showcase your organization to an international audience. There are a variety of opportunities available to suit your needs. For more information, contact Sharon Nakama at snakama@ptc.org.

## PTC'07 Checklist

This checklist is to be used as a quick reference for PTC'07 deadlines.

**Confirmation of Exhibit Space**

Signed contract and 50% deposit of the total exhibit space to PTC. If exhibit space is rented after 1 November 2006, payment must be submitted in full. PTC will return a receipt as confirmation.

**Full Payment of Exhibit Space**

Due by **1 November 2006**.

**Company Description and Logo**

Due by **30 November 2006**.

**Exhibitor Badge List**

Due by **30 November 2006**.

**Telecommunications Order Forms and High Speed Internet**

The Hilton must receive requests in writing by **30 November 2006**.

**Hilton Room Reservations**

Reservations must be received by **14 December 2006** to qualify for the PTC rate, based on space availability.

**ICES**

Advance Price Deadline is **15 December 2006**.



## Questions?

For further information contact:

Neil Bock  
Director of Sales  
Pacific Telecommunications Council

Tel: +1.508.870.9787  
Fax: +1.508.870.9777  
Email: neil@ptc.org  
Website: www.ptc07.org

# PTC'07 EXHIBIT RULES AND REGULATIONS

## 1. ASSIGNMENT OF EXHIBIT SPACE

Booth assignment priority will be determined by the date of receipt of the signed Exhibitor Contract and a 50% deposit of the total exhibit booth rental. Applicants are requested to select three (3) location preferences. In the event that all location preferences are committed, PTC will assign a location.

## 2. CONTRACT FOR EXHIBIT SPACE

1) The enclosed contract for space, the formal notice of space assignment by PTC, and the full payment of rental charges together constitute a contract for the right to use exhibit space at PTC'07. PTC reserves the right to reassign the exhibit space allotted under such contract, 2) change exhibit location assignments when such action is deemed in the best interest of the Exhibition. If PTC and the Exhibitor are unable to mutually agree on a relocation, the Exhibitor shall be entitled to a refund.

## 3. PAYMENT FOR EXHIBIT SPACE

A deposit of 50% of the cost of the space is due when the contract is submitted, and the balance of the payment is due upon notification of exhibit space assignment, and must be paid no later than 1 November 2006. If exhibit space is rented after 1 November 2006, payment must be submitted in full with the signed Exhibitor Contract. If these deadlines are not met, the Exhibitor's rights to exhibit may be cancelled without further notice or refund of any deposit. Payments are non-transferable.

PTC will accept the following methods of payment: 1) check; 2) credit card; 3) bank transfer and 4) purchase order (credit card authorization must accompany P.O.). Payments accepted in U.S. currency.

If you wish to pay by bank wire transfer, please contact Linda Ristow at linda@ptc.org or tel.: +1.808.941.3789 x109 for banking information.

**Please add US\$20 for payments made by bank transfer, to cover bank charges.**

## 4. CANCELLATIONS OF EXHIBIT SPACE

Cancellations must be received in writing to receive any refund according to the following schedule:

- Cancellations made from 17 October 2006 through 15 November 2006 are subject to a 50% cancellation charge of the total rental fee.
- Cancellations made from 16 November 2006 are subject to a 100% cancellation charge of the total rental fee.

PTC reserves the right to resell any exhibit booth space that has been previously cancelled regardless of whether or not a refund is owed to the cancelled Exhibitor.

In the event that PTC'07 is not held, for any reason whatsoever, the rental and lease of space to the Exhibitor shall be terminated, and the sole liability of PTC will be limited to refund the amount previously paid under the contract.

## 5. EXHIBIT SPACE

All exhibit booth spaces are 8' x 10' (depth x width), 2.44m x 3.05m (approximately 80 square feet). More than one exhibit space may be rented. Each Exhibitor is furnished with standard chrome supports and aisle posts with an 8 feet (2.44 meters) high back divider and 3 feet (.91 meter) high side dividers from which flame-proof drapes are suspended (diagram a). A standard sign (7" x 44" / 17.8 cm x 111.8 cm) will be furnished with the booth number and the Exhibitor's name by the exhibitor contractor, ICES.

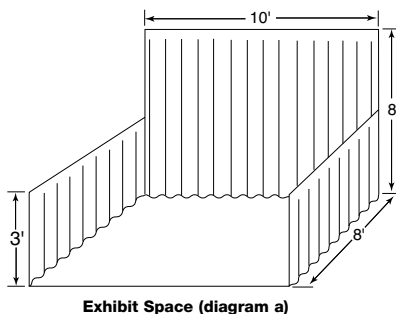
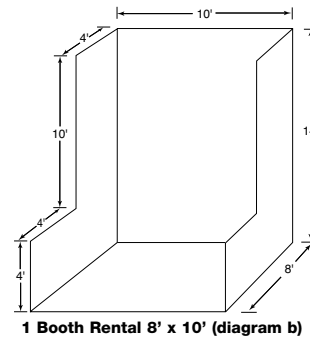

Exhibit Space (diagram a)

## 6. RESTRICTIONS

**No Exhibitor is permitted to block the line-of-sight of neighboring exhibits.** The exhibit back wall must not exceed the height limit of 14' and the side walls must not extend the height of 14' nor extend from the back wall more than one-half of the depth of space. The remaining 4' of space must not exceed the height of 4' (diagram b & c). 8' (deep) x 20' (wide) endcaps/peninsula booths (booths which face three aisles) are not permitted at PTC'07. REASON: The back wall of these booths would block the line-of-sight of the neighboring exhibits.



1 Booth Rental 8' x 10' (diagram b)

Endcap/peninsula booths and two-sided booths (booths which face parallel aisles), comprised of 4 or more exhibit spaces arranged in a square or rectangle (ex. 16' x 20') are permitted. However, exhibits must maintain the 4' height requirement within the 4' of space on the left and right or parallel aisles (diagram d). Any exhibit booth with this floor configuration (diagram d) must obtain design approval from the PTC office. Any special or unusual exhibit construction or installation must be pre-approved by PTC.

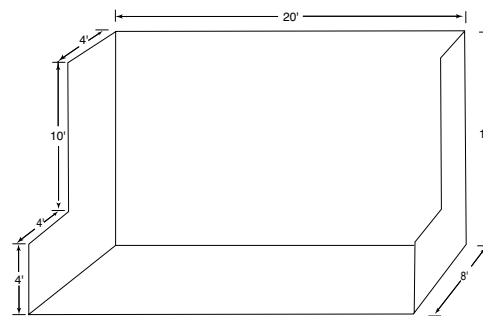

2 booth rental 8' x 20' (diagram c)

All display materials must be flameproof and are subject to inspection by the Honolulu, Hawaii Fire Department. No flammable fluids or substances may be used or shown in booths.

Gasoline-driven vehicles must be drained of gasoline prior to being moved onto the premises. The battery must be disconnected and the cable taped.

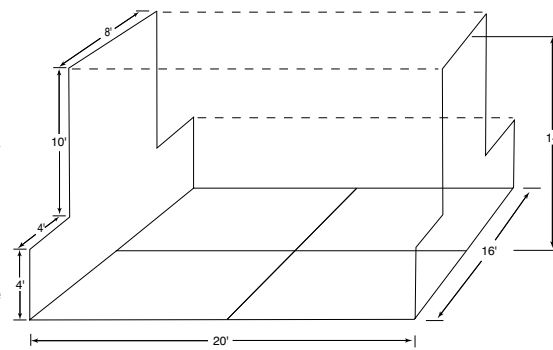

Display of height restrictions - not limited to this design (diagram d)

## 7. BOOTH PERSONNEL AND ACCESS

Booth personnel are required to wear their badges at all times while in the Exhibit Hall. **BADGES ARE NON-TRANSFERABLE. PTC staff and security will refuse entry and escort out any person not wearing an appropriate badge.** PTC reserves the right to confiscate misused booth-personnel badges. PTC will issue Exhibitor Badges to individuals staffing the exhibit booth. Each 8'x10' booth space rented, is allowed up to 6 complimentary Exhibitor Badges. Additional Exhibitor Badges may be purchased for \$20 each. There will be a US\$50 charge to replace badges. Exhibitors interested in attending the conference sessions must register for the conference separately and pay the appropriate member/non-member conference registration fees.

Exhibitor personnel will only be permitted in the exhibit hall during scheduled set-up hours and 1 hour prior to and after the scheduled exhibit hours, unless prior arrangements have been made with PTC. For security reasons, Exhibitor Badges are required to enter the exhibition area during non-exhibit hours.

# PTC'07 EXHIBIT RULES AND REGULATIONS

Badges and the Exhibitor Packet are available for pick-up onsite at the Exhibitor Registration Desk during the following dates and times:

## Exhibitor Registration

Saturday, 13 January 2007	1500 – 1800
Sunday, 14 January 2007	0800 – 1800
Monday, 15 January 2007	0730 – 1800
Tuesday, 16 January 2007	0800 – 1900
Wednesday, 17 January 2007	0800 – 1200

Exhibitor will provide the names of exhibit personnel who will require Exhibitor Badges no later than 30 November 2006. Exhibitor representatives are restricted to personnel engaged in the display, demonstration and sales of the company's products or services. Exhibitors may not permit non-exhibiting company representatives to exhibit in their booth. Those involved only in the set-up of the booth will be issued a temporary pass to access the exhibitor hall during assembling hours, exhibitors are required to provide their names to PTC in advance.

## 8. EXHIBITOR SERVICES

Furniture, labor, electrical power, drayage, signs, other booth furnishings and other support services may be ordered at standard rates from the official contractor, ICES. Complete details will be forwarded to each exhibitor following confirmation, booth payment and the assignment of booth space. A service desk will be maintained by the contractor in the exhibit area.

For further information, please contact:

ICES  
Attn: Tanya Lasconia  
1004 Makepono Street  
Honolulu, HI 96819 USA  
Tel: +1.808.832.2440  
Fax: +1.808.832.2431  
Email: tanya@iceshawaii.com

Any display requiring special set-up not provided by ICES must receive prior permission from the hotel and/or PTC staff.

## 9. ASSEMBLING AND DISMANTLING RESTRICTIONS

### Installation of Exhibit Booths:

Sunday, 14 January 2007	0800 – 1800
Monday, 15 January 2007	0730 – 1000

Exhibit booths must be completely assembled by 1000, Monday, 15 January 2007. Exhibitors are required to check-in and pick up their exhibitor badges at the Exhibit Registration Booth located in the Coral Lounge, 6th Floor of the Mid-Pacific Conference Center prior to setting up their booth.

Access into the exhibit hall for set-up, dismantling and during non-exhibit hours require an exhibitor badge. For exhibit booth display restrictions, please refer to the PTC'07 Exhibit Rules and Regulations. In the event that your exhibit booth has not been assembled before the exhibits open, or if your organization fails to set-up a booth, or you do not comply with the stated exhibit restrictions your Exhibitor benefits will be forfeited.

### Dismantling of Exhibit Booths:

Tuesday, 16 January 2007	1930 – 2130
Wednesday, 17 January 2007	0800 – 1100

Your exhibit booth must be dismantled and moved out of the exhibit hall by 1100, Wednesday, 17 January 2007. ICES, PTC's official exhibitor contractor will work with you directly to ensure a timely move-out. Exhibitors are responsible for their exhibit material until it is moved out of the exhibit area. Exhibitor agrees to abide by rules and policies set by ICES / PTC for the move out of booth materials.

During move out, a Bill of Lading must be completed for material leaving the exhibit hall (including hand carried items). All freight couriers must check in with the ICES service desk and sign a Bill of Lading for the shipment.

In the event that your exhibit booth has not been dismantled by 1100 on Wednesday, 17 January 2007, your Exhibitor benefits will be forfeited. Damages to the exhibit hall as a result of improper Exhibitor exhibit

installation or dismantling will be the responsibility of the exhibitor.

## 10. USE OF EXHIBIT SPACE

- (a) No Exhibitor shall assign, sublet, or share the space assigned without the consent of PTC. Additional charges may apply. Exhibitors must display goods or services manufactured or dealt with by them in their regular course of business, unless otherwise approved by PTC. Exhibit space is for the sole use of the exhibitor named in the contract. **Exhibitors may not permit non-exhibiting company representatives to exhibit in their booth.** All companies represented in the exhibition area must be separately contracted for their own exhibit space. Only contracted companies are entitled to a listing in the program and Conference Website.
- (b) In the event that the Exhibitor fails to install or have installed its display within the time limit set prior to the opening of PTC'07 or fails to comply with any provisions concerning the use of the display space, PTC shall have the right to take possession of said space and resell same, or any part thereof.
- (c) All demonstrations and distribution of circulars and promotional materials must be confined to the limits of the Exhibitor's booth.
- (d) Exhibits that include the operation of musical equipment, radios, sound motion picture equipment, public address systems, or any noise are not permitted to annoy or disturb adjacent Exhibitors, and must be preapproved by PTC.
- (e) Exhibitors are required to have their exhibit space neat and orderly at all times.
- (f) An attendant must be in charge of the exhibit display during the scheduled exhibit hours. Crowd control/admittance security service will be provided by PTC when the area is closed to the public.
- (g) No distribution/consumption of alcohol is permitted in the exhibition hall except during the Marketplace Reception.
- (h) No meetings may take place during non-exhibit hours in the exhibit area.

## 11. LIMITATION ON LIABILITY

PTC makes no warranties or representations of any kind, whether expressed or implied, for its services and for PTC'07. Except as otherwise provided therein, in no event whatsoever shall PTC be liable to the Exhibitor for any direct, indirect, incidental, special, consequential, punitive, exemplary or similar damages arising out of or in connection with the conduct or cancellation of PTC'07, including, but not limited to, loss of business profits, business interruption, electronically transmitted data, and the like, even if the Exhibitor has been advised of the possibility of such damages.

The Exhibitor understands and agrees that PTC, its officers, agents or employees shall not in any manner be responsible for the loss, theft or damage to any of the goods, wares, chattels, or equipment exhibited in the Exhibitors allotted space or placed therein, or while in transit to or from the building. The exhibit of the Exhibitor as well as all of its personal property situated in the allotted space remains therein at the sole risk of the Exhibitor.

The Exhibitor further specifically agrees that it will exhibit its products, accessories, supplies, and equipment in such a manner as not to cause injury to the public, visitors, guests, employees, or any other person on the premises. The Exhibitor agrees to indemnify and hold harmless PTC, its officers, agents, and employees from any claims or claim of any nature whatsoever arising by reason of any damage sustained by any person, or to any property upon said premises.

# MID-PACIFIC MARKETPLACE PTC'07 EXHIBIT HALL

Hilton Hawaiian Village® Beach Resort & Spa  
Mid-Pacific Conference Center, 6th Floor  
(Layout subject to change)

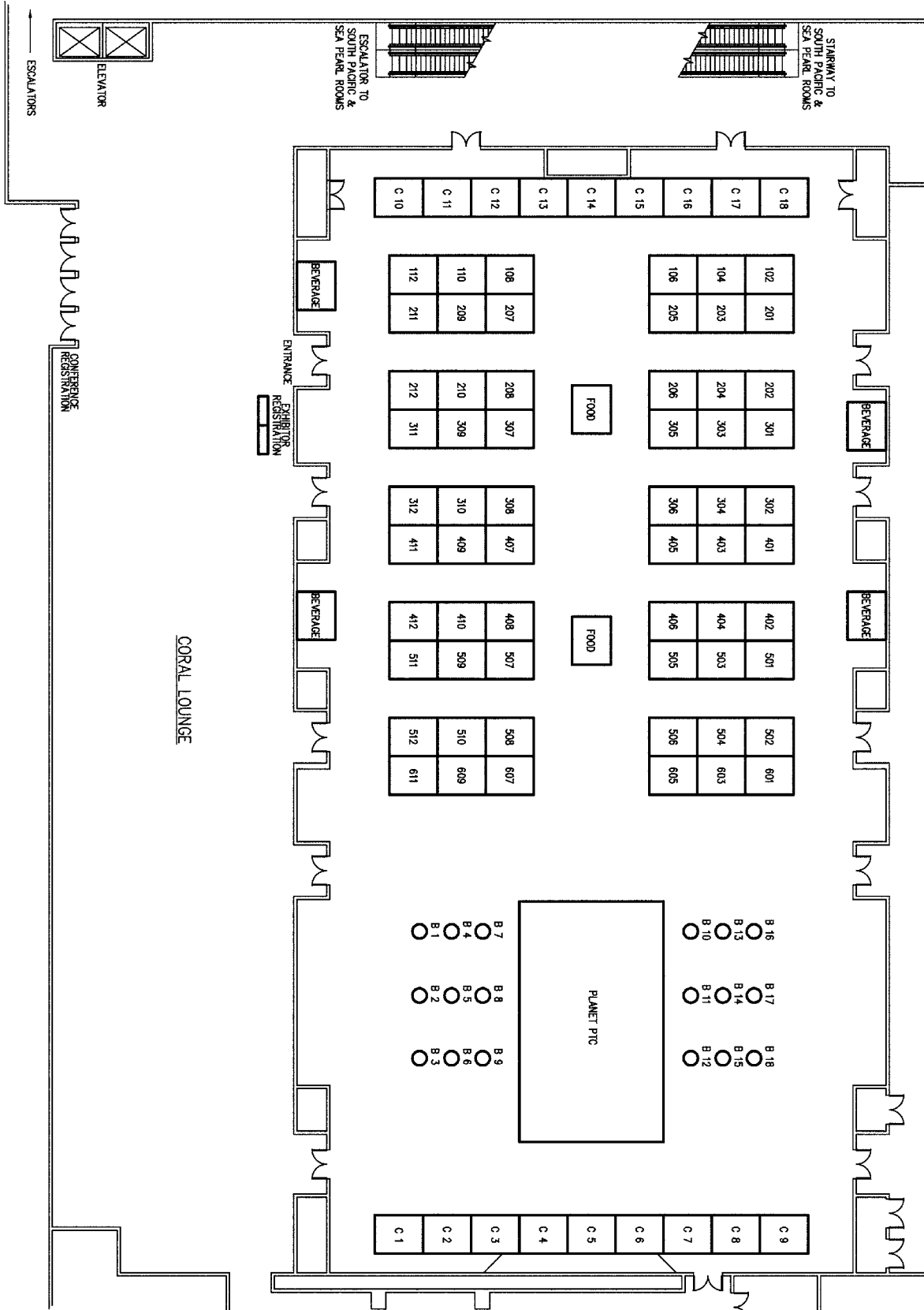

B = One-2-One Exchange Meeting Table  
C = Conference Cubicle Meeting Room